

Determination of SILVERSTAR glazing characteristics

Version information:
 Program 3.10
 Database 3.54
 Output format 3.21

The following characteristics are calculated with the program SILVERSTAR glaCE.

Project:

Company: Interglas

Employee: LA

Customer:

Product: 4EWNGEN2P4EWNG4EWNGEN2P

Date: 27.10.2020

Glazing:

Window tilt angle: 90 °

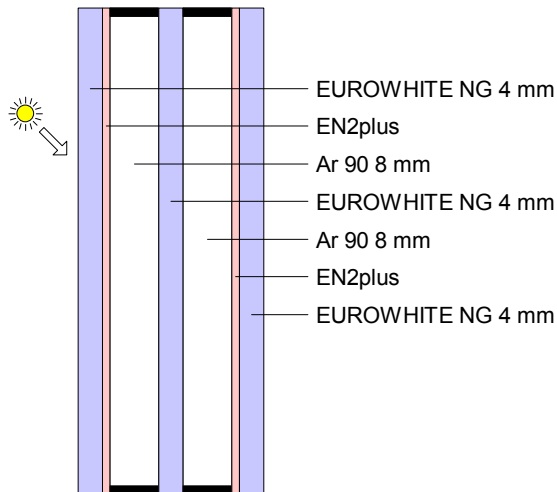

Comments:

Calculated glazing characteristics:

Thermal transmittance Ug:	0.9804 W/m ² K	EN 673:2011	
Total solar energy transmittance (solar factor g):	55.515 %	EN 410:2011	
Light transmittance:	76.056 %		
Light reflectance (outside):	14.737 %		
Light reflectance (inside):	14.737 %		
Light absorptance:	9.207 %		
Solar direct transmittance:	50.834 %		
Solar direct reflectance (outside):	34.624 %		
Solar direct absorptance:	14.542 %		
Secondary internal heat transfer factor:	4.681 %		
UV-Transmittance:	18.687 %		
UV-Reflectance:	29.019 %		
UV-Absorptance:	52.294 %		
General colour rendering index (transmission):	98.942		
Selectivity (light transmittance / solar factor g):	1.3700		
Shading coefficient (solar factor g / 0.87):	63.810 %		
Shading coefficient (solar factor g / 0.8):	69.393 %		

The values given are only indicative and subject to change without notice.
 They do not represent any guarantee for the performance of the glazing
 Calculations are performed according to the European standards EN 410:2011 and EN 673:2011.

Determination of SILVERSTAR glazing characteristics

Version information:
 Program 3.10
 Database 3.54
 Output format 3.21

The following characteristics are calculated with the program SILVERSTAR glaCE.

Project:

Company: Interglas

Employee: LA

Customer:

Product: 4EWNGEN2P4EWNG4EWNGEN2P

Date: 27.10.2020

Glazing:

Window tilt angle: 90 °

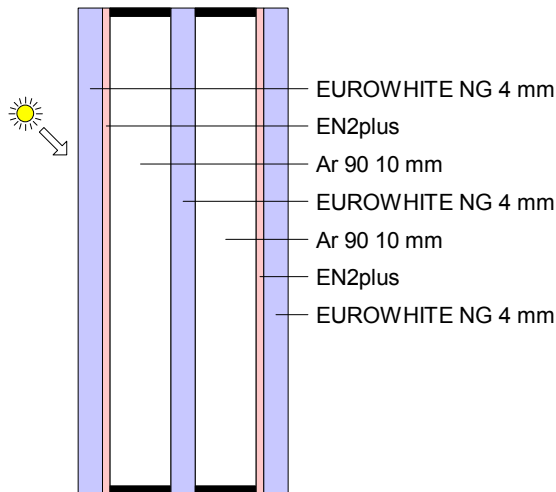

Comments:

Calculated glazing characteristics:

Thermal transmittance Ug:	0.8264 W/m ² K	EN 673:2011	
Total solar energy transmittance (solar factor g):	55.554 %	EN 410:2011	
Light transmittance:	76.056 %		
Light reflectance (outside):	14.737 %		
Light reflectance (inside):	14.737 %		
Light absorptance:	9.207 %		
Solar direct transmittance:	50.834 %		
Solar direct reflectance (outside):	34.624 %		
Solar direct absorptance:	14.542 %		
Secondary internal heat transfer factor:	4.721 %		
UV-Transmittance:	18.687 %		
UV-Reflectance:	29.019 %		
UV-Absorptance:	52.294 %		
General colour rendering index (transmission):	98.942		
Selectivity (light transmittance / solar factor g):	1.3690		
Shading coefficient (solar factor g / 0.87):	63.855 %		
Shading coefficient (solar factor g / 0.8):	69.443 %		

The values given are only indicative and subject to change without notice.
 They do not represent any guarantee for the performance of the glazing
 Calculations are performed according to the European standards EN 410:2011 and EN 673:2011.

Determination of SILVERSTAR glazing characteristics

Version information:
 Program 3.10
 Database 3.54
 Output format 3.21

The following characteristics are calculated with the program SILVERSTAR glaCE.

Project:

Company: Interglas

Employee: LA

Customer:

Product: 4EWNGEN2P4EWNG4EWNGEN2P

Date: 27.10.2020

Glazing:

Window tilt angle: 90 °

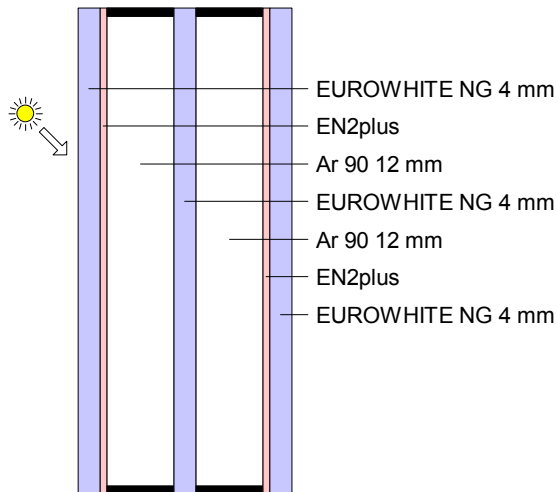

Comments:

Calculated glazing characteristics:

Thermal transmittance Ug:	0.7177 W/m ² K	EN 673:2011	
Total solar energy transmittance (solar factor g):	55.582 %	EN 410:2011	
Light transmittance:	76.056 %		
Light reflectance (outside):	14.737 %		
Light reflectance (inside):	14.737 %		
Light absorptance:	9.207 %		
Solar direct transmittance:	50.834 %		
Solar direct reflectance (outside):	34.624 %		
Solar direct absorptance:	14.542 %		
Secondary internal heat transfer factor:	4.748 %		
UV-Transmittance:	18.687 %		
UV-Reflectance:	29.019 %		
UV-Absorptance:	52.294 %		
General colour rendering index (transmission):	98.942		
Selectivity (light transmittance / solar factor g):	1.3684		
Shading coefficient (solar factor g / 0.87):	63.887 %		
Shading coefficient (solar factor g / 0.8):	69.478 %		

The values given are only indicative and subject to change without notice.
 They do not represent any guarantee for the performance of the glazing
 Calculations are performed according to the European standards EN 410:2011 and EN 673:2011.

Determination of SILVERSTAR glazing characteristics

Version information:
 Program 3.10
 Database 3.54
 Output format 3.21

The following characteristics are calculated with the program SILVERSTAR glaCE.

Project:

Company: Interglas

Employee: LA

Customer:

Product: 4EWNGEN2P4EWNG4EWNGEN2P

Date: 27.10.2020

Glazing:

Window tilt angle: 90 °

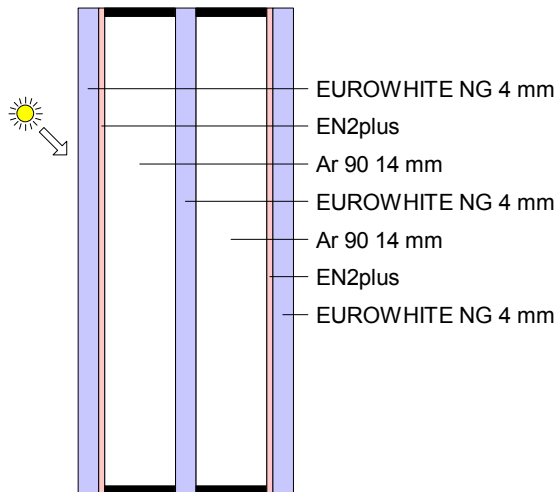

Comments:

Calculated glazing characteristics:

Thermal transmittance Ug:	0.6369 W/m ² K	EN 673:2011	
Total solar energy transmittance (solar factor g):	55.603 %	EN 410:2011	
Light transmittance:	76.056 %		
Light reflectance (outside):	14.737 %		
Light reflectance (inside):	14.737 %		
Light absorptance:	9.207 %		
Solar direct transmittance:	50.834 %		
Solar direct reflectance (outside):	34.624 %		
Solar direct absorptance:	14.542 %		
Secondary internal heat transfer factor:	4.769 %		
UV-Transmittance:	18.687 %		
UV-Reflectance:	29.019 %		
UV-Absorptance:	52.294 %		
General colour rendering index (transmission):	98.942		
Selectivity (light transmittance / solar factor g):	1.3678		
Shading coefficient (solar factor g / 0.87):	63.911 %		
Shading coefficient (solar factor g / 0.8):	69.503 %		

The values given are only indicative and subject to change without notice.
 They do not represent any guarantee for the performance of the glazing
 Calculations are performed according to the European standards EN 410:2011 and EN 673:2011.

Determination of SILVERSTAR glazing characteristics

Version information:
 Program 3.10
 Database 3.54
 Output format 3.21

The following characteristics are calculated with the program SILVERSTAR glaCE.

Project:

Company: Interglas

Employee: LA

Customer:

Product: 4EWNGEN2P4EWNG4EWNGEN2P

Date: 27.10.2020

Glazing:

Window tilt angle: 90 °

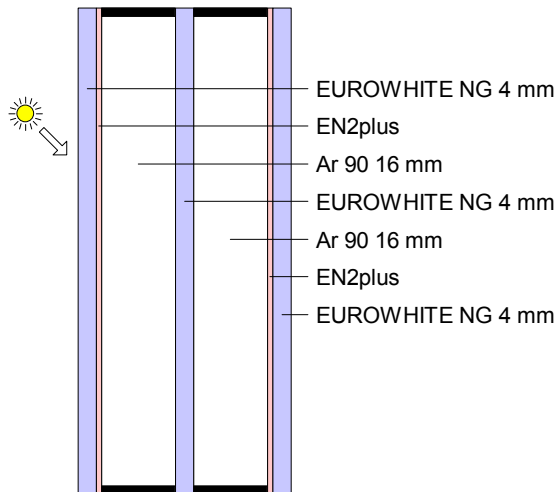

Comments:

Calculated glazing characteristics:

Thermal transmittance Ug:	0.5745 W/m ² K	EN 673:2011	
Total solar energy transmittance (solar factor g):	55.619 %	EN 410:2011	
Light transmittance:	76.056 %		
Light reflectance (outside):	14.737 %		
Light reflectance (inside):	14.737 %		
Light absorptance:	9.207 %		
Solar direct transmittance:	50.834 %		
Solar direct reflectance (outside):	34.624 %		
Solar direct absorptance:	14.542 %		
Secondary internal heat transfer factor:	4.785 %		
UV-Transmittance:	18.687 %		
UV-Reflectance:	29.019 %		
UV-Absorptance:	52.294 %		
General colour rendering index (transmission):	98.942		
Selectivity (light transmittance / solar factor g):	1.3675		
Shading coefficient (solar factor g / 0.87):	63.930 %		
Shading coefficient (solar factor g / 0.8):	69.523 %		

The values given are only indicative and subject to change without notice.
 They do not represent any guarantee for the performance of the glazing
 Calculations are performed according to the European standards EN 410:2011 and EN 673:2011.

Determination of SILVERSTAR glazing characteristics

Version information:
 Program 3.10
 Database 3.54
 Output format 3.21

The following characteristics are calculated with the program SILVERSTAR glaCE.

Project:

Company: Interglas

Employee: LA

Customer:

Product: 4EWNGEN2P4EWNG4EWNGEN2P

Date: 27.10.2020

Glazing:

Window tilt angle: 90 °

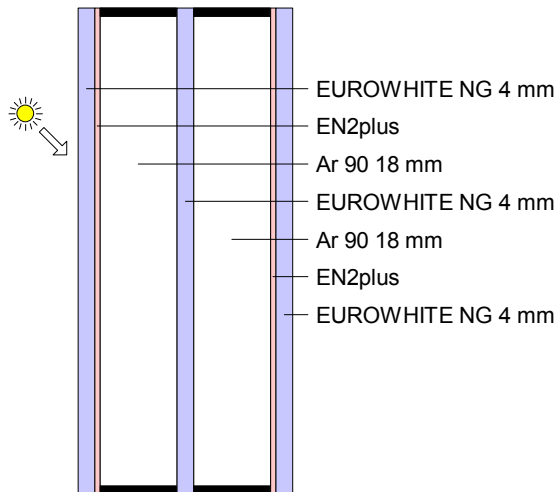

Comments:

Calculated glazing characteristics:

Thermal transmittance Ug:	0.5249 W/m ² K	EN 673:2011	
Total solar energy transmittance (solar factor g):	55.631 %	EN 410:2011	
Light transmittance:	76.056 %		
Light reflectance (outside):	14.737 %		
Light reflectance (inside):	14.737 %		
Light absorptance:	9.207 %		
Solar direct transmittance:	50.834 %		
Solar direct reflectance (outside):	34.624 %		
Solar direct absorptance:	14.542 %		
Secondary internal heat transfer factor:	4.798 %		
UV-Transmittance:	18.687 %		
UV-Reflectance:	29.019 %		
UV-Absorptance:	52.294 %		
General colour rendering index (transmission):	98.942		
Selectivity (light transmittance / solar factor g):	1.3671		
Shading coefficient (solar factor g / 0.87):	63.944 %		
Shading coefficient (solar factor g / 0.8):	69.539 %		

The values given are only indicative and subject to change without notice.
 They do not represent any guarantee for the performance of the glazing
 Calculations are performed according to the European standards EN 410:2011 and EN 673:2011.

Determination of SILVERSTAR glazing characteristics

Version information:
 Program 3.10
 Database 3.54
 Output format 3.21

The following characteristics are calculated with the program SILVERSTAR glaCE.

Project:

Company: Interglas

Employee: LA

Customer:

Product: 4EWNGEN2P4EWNG4EWNGEN2P

Date: 27.10.2020

Glazing:

Window tilt angle: 90 °

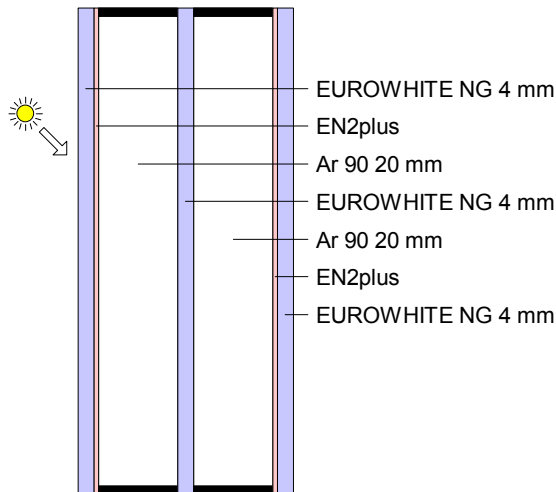

Comments:

Calculated glazing characteristics:

Thermal transmittance Ug:	0.5188 W/m ² K	EN 673:2011	
Total solar energy transmittance (solar factor g):	55.633 %	EN 410:2011	
Light transmittance:	76.056 %		
Light reflectance (outside):	14.737 %		
Light reflectance (inside):	14.737 %		
Light absorptance:	9.207 %		
Solar direct transmittance:	50.834 %		
Solar direct reflectance (outside):	34.624 %		
Solar direct absorptance:	14.542 %		
Secondary internal heat transfer factor:	4.799 %		
UV-Transmittance:	18.687 %		
UV-Reflectance:	29.019 %		
UV-Absorptance:	52.294 %		
General colour rendering index (transmission):	98.942		
Selectivity (light transmittance / solar factor g):	1.3671		
Shading coefficient (solar factor g / 0.87):	63.946 %		
Shading coefficient (solar factor g / 0.8):	69.541 %		

The values given are only indicative and subject to change without notice.
 They do not represent any guarantee for the performance of the glazing
 Calculations are performed according to the European standards EN 410:2011 and EN 673:2011.

Determination of SILVERSTAR glazing characteristics

Version information:
 Program 3.10
 Database 3.54
 Output format 3.21

The following characteristics are calculated with the program SILVERSTAR glaCE.

Project:

Company: Interglas

Employee: LA

Customer:

Product: 4EWNGEN2P4EWNG4EWNGEN2P

Date: 27.10.2020

Glazing:

Window tilt angle: 90 °

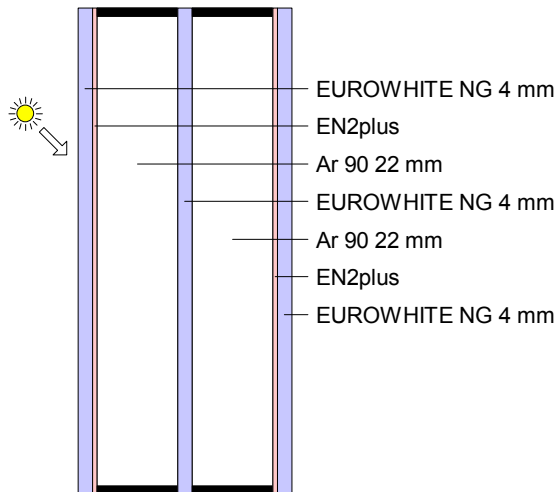

Comments:

Calculated glazing characteristics:

Thermal transmittance Ug:	0.5242 W/m ² K	EN 673:2011	
Total solar energy transmittance (solar factor g):	55.632 %	EN 410:2011	
Light transmittance:	76.056 %		
Light reflectance (outside):	14.737 %		
Light reflectance (inside):	14.737 %		
Light absorptance:	9.207 %		
Solar direct transmittance:	50.834 %		
Solar direct reflectance (outside):	34.624 %		
Solar direct absorptance:	14.542 %		
Secondary internal heat transfer factor:	4.798 %		
UV-Transmittance:	18.687 %		
UV-Reflectance:	29.019 %		
UV-Absorptance:	52.294 %		
General colour rendering index (transmission):	98.942		
Selectivity (light transmittance / solar factor g):	1.3671		
Shading coefficient (solar factor g / 0.87):	63.944 %		
Shading coefficient (solar factor g / 0.8):	69.540 %		

The values given are only indicative and subject to change without notice.
 They do not represent any guarantee for the performance of the glazing
 Calculations are performed according to the European standards EN 410:2011 and EN 673:2011.

Determination of SILVERSTAR glazing characteristics

Version information:
 Program 3.10
 Database 3.54
 Output format 3.21

The following characteristics are calculated with the program SILVERSTAR glaCE.

Project:

Company: Interglas

Employee: LA

Customer:

Product: 4EWNGEN2P4EWNG4EWNGEN2P

Date: 29.10.2020

Glazing:

Window tilt angle: 90 °

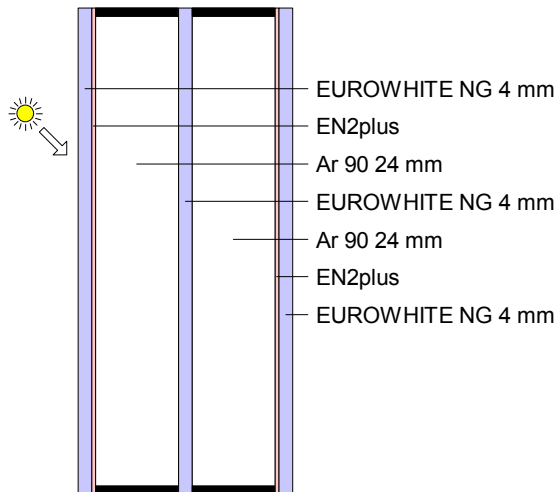

Comments:

Calculated glazing characteristics:

Thermal transmittance Ug:	0.5291 W/m ² K	EN 673:2011	
Total solar energy transmittance (solar factor g):	55.630 %	EN 410:2011	
Light transmittance:	76.056 %		
Light reflectance (outside):	14.737 %		
Light reflectance (inside):	14.737 %		
Light absorptance:	9.207 %		
Solar direct transmittance:	50.834 %		
Solar direct reflectance (outside):	34.624 %		
Solar direct absorptance:	14.542 %		
Secondary internal heat transfer factor:	4.797 %		
UV-Transmittance:	18.687 %		
UV-Reflectance:	29.019 %		
UV-Absorptance:	52.294 %		
General colour rendering index (transmission):	98.942		
Selectivity (light transmittance / solar factor g):	1.3672		
Shading coefficient (solar factor g / 0.87):	63.943 %		
Shading coefficient (solar factor g / 0.8):	69.538 %		

The values given are only indicative and subject to change without notice.
 They do not represent any guarantee for the performance of the glazing
 Calculations are performed according to the European standards EN 410:2011 and EN 673:2011.